

SHOWER FLOOR
MODEL NO. () SIZE ()

Shower Floor shall be of Williams precast terrazzo. Terrazzo shall be made of black and white marble chips cast in white portland cement to produce a compressive strength of not less than 3000 PSI, seven days after casting. Terrazzo surface shall be ground smooth, grouted and sealed to resist stain. Flange, cast integral shall be of galvanized bonderized steel and shall extend not less than one inch above the shoulder, Shoulder shall be not less than two inches wide. Drain body shall be cast integral, and shall provide for a caulked lead connection not less than one inch deep to a two inch pipe. Removable type strainer plate shall be made of stainless steel.

STERN
WILLIAMS
SERPENTINE
 HANDICAP ACCESSIBLE
 SHOWER FLOORS
ARCHITECTURAL
SPECIFICATIONS



SERPENTINE SHOWER FLOOR
 — Three sides flanged —

MODEL	SIZE
WH-2200	36" x 36"
WH-2400	40" x 40"
WH-2500	42" x 42"
WH-2600	48" x 36"
WH-2700	48" x 48"
WH-2800	60" x 32"
WH-2900	60" x 34"
WH-3000	46" x 52"

JOB

ENGINEER

LOCATION

CONTRACTOR

PROJECT:

SHOWER FLOOR (REDUCED THRESHOLD)

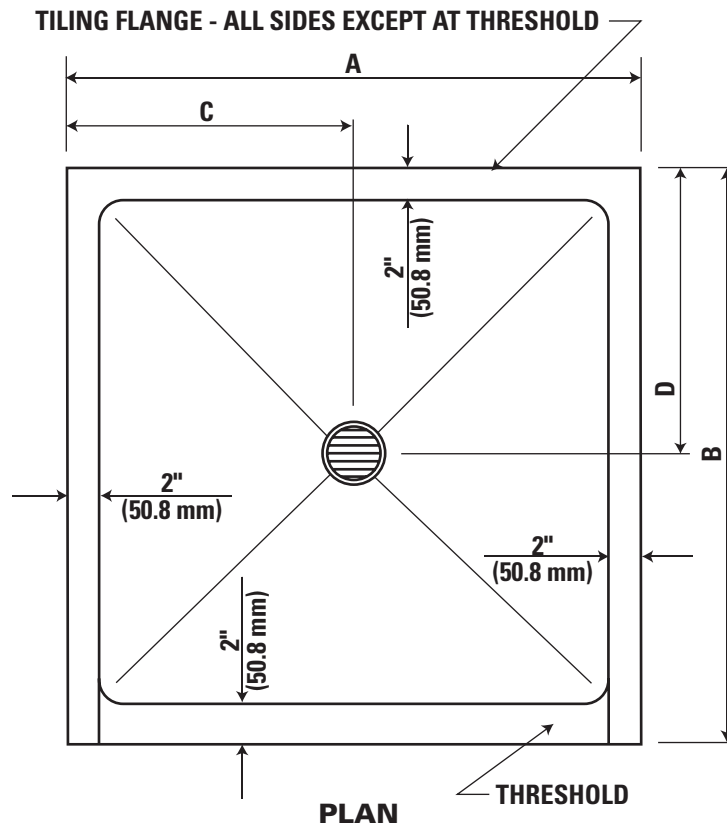
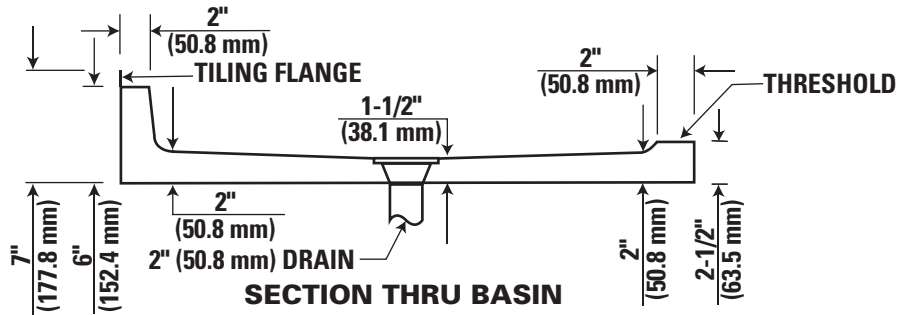

MODEL	A		B		C		D	
	IN	MM	IN	MM	IN	MM	IN	MM
WH-2200	36	914.4	36	914.4	18	457.2	18	457.2
WH-2400	40	1,016	40	1,016	20	508	20	508
WH-2500	42	1,066.8	42	1,066.8	21	533.4	21	533.4
WH-2600	48	1,219.2	36	914.4	24	609.6	18	457.2
WH-2700	48	1,219.2	48	1,219.2	24	609.6	24	609.6
WH-2800	60	1,524	32	812.8	30	762	16	406.4
WH-2900	60	1,524	34	863.6	30	762	17	431.8
WH-3000	46	1,168.4	52	1,320.8	23	584.2	8	203.2

- Note:**
1. For Barrier-Free installation, contractor shall provide recess for curb.
 2. All dimensions subject to manufacturing variance of plus or minus 1/4".

Note: All dimensions subject to manufacturing variance of plus or minus 1/4" (6 MM).