

**STANDARD EQUIPMENT FOR FIELD INSTALLATION**

KEY NO.	QTY.	DESCRIPTION
1	1	40" X 40" BASE
2	3	36-9/16" X 77-3/16" PANEL
3	2	CORNER JOINT
4	1	TOP FRAME
—	1	ROD AND CURTAIN
—	1	PRESSURE BALANCED VALVE WITH STOPS
—	1	HAND HELD SHOWER HEAD WITH SWIVEL CONNECTOR, SUPPLY ELL, VACUUM BREAKER AND 69" C.P. FLEXIBLE BRASS HOSE
—	1	24" C.P. BRASS SLIDE BAR WITH ADJUSTABLE SHOWER HEAD MOUNTING BRACKET AND MOUNTING SCREWS.
—	1	HORIZONTAL WRAP AROUND STAINLESS STEEL GRAB BAR
—	1	VERTICAL STAINLESS STEEL GRAB BAR
—	1	RETRACTABLE HANDICAPPED SHOWER SEAT WITH STAINLESS STEEL FRAME

**FOR CORRECT INSTALLATION:**

1. ESTABLISH PROPER CLEARANCE BETWEEN SHOWER BASE AND WALLS.
2. SET SHOWER BASE ON MORTAR BED AND CAREFULLY LEVEL TO AVOID PROBLEMS OF UNEVEN SUB FLOOR.

**OPTIONS**

- FRONT FILLER STRIP (KEY NO. 6)
- FILLER STRIP (KEY NO. 7)
- FINISH:
  - POWDER COAT ON GALVANIZED STEEL
  - HIGH DENSITY POLYMER (H.D.P.)
  - STAINLESS STEEL
  - SOLID PHENOLIC CORE (S.P.C.)
- THERMOSTATIC VALVE
- TOP COVER
- TOP COVER WITH LIGHT
- VALVE BY OTHERS
- COLOR:
  - WHITE
  - OPTIONAL

**WE SUGGEST A FLOOR DRAIN AT THE ENTRANCE TO THE WHEELCHAIR SHOWER FLOOR**

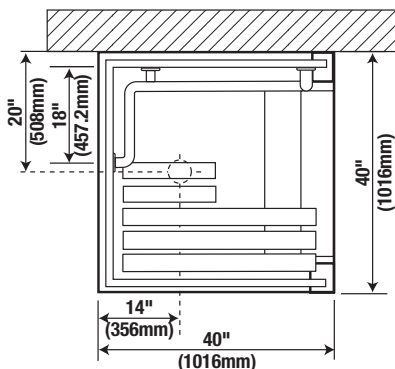
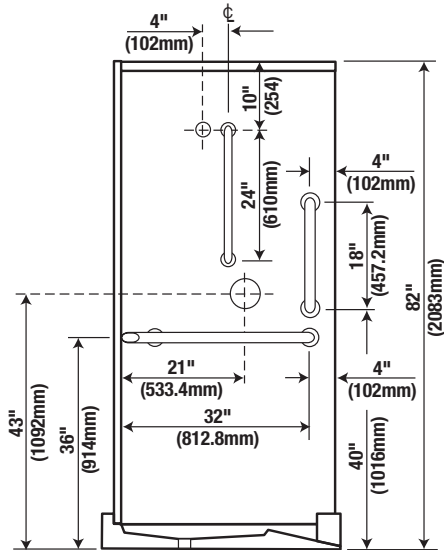

Note: All dimensions subject to manufacturing variance of plus or minus 1/4" (6 MM).